

GLACIÄR X5 ACCESSORIES

Type 3 and Type 5 Duct Adapter

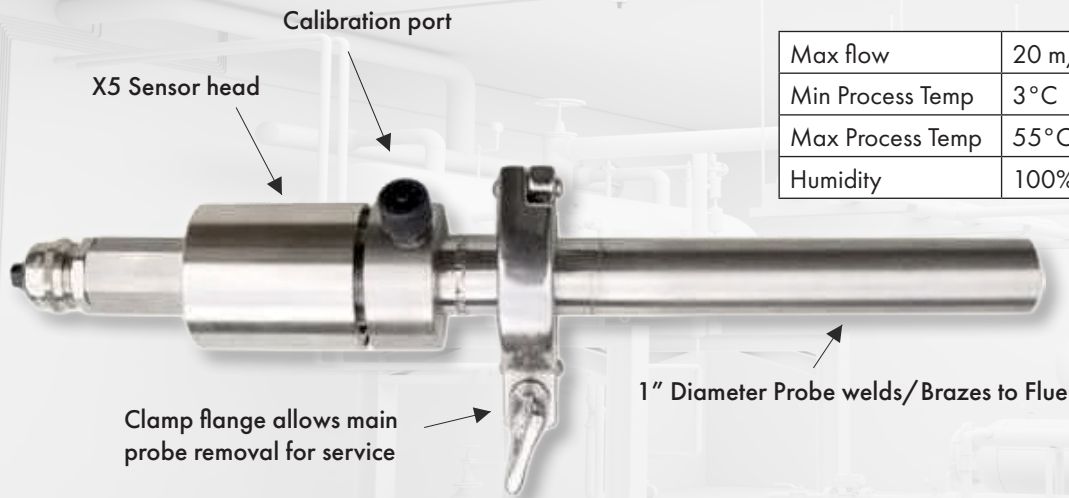

Max flow	20 m/s
Min Process Temp	3°C
Max Process Temp	55°C
Humidity	100% RH Non Condensing

Type 3 and Type 5 duct adaptors rely on gas diffusion to the detector. Typical applications are head space monitoring in tanks, vessels or duct work. The clamp flange arrangement allows easy removal of the detector for service. Internal baffles protect the detector.

TYPICAL APPLICATIONS

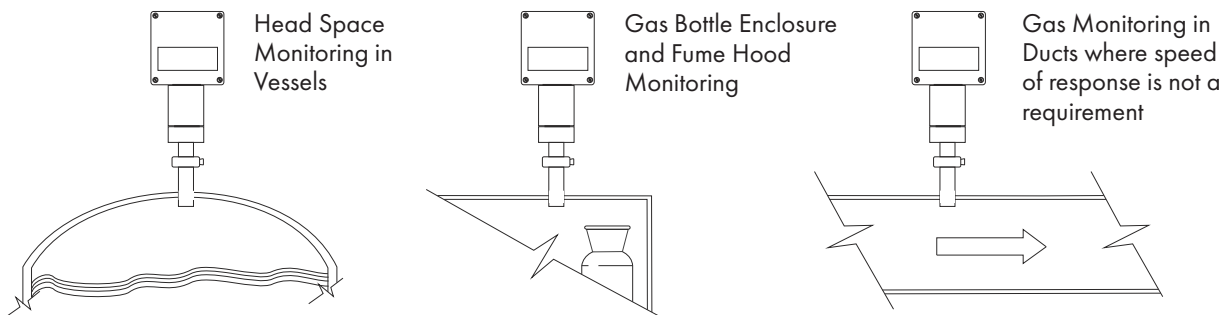

TYPICAL MOUNTING DETAILS

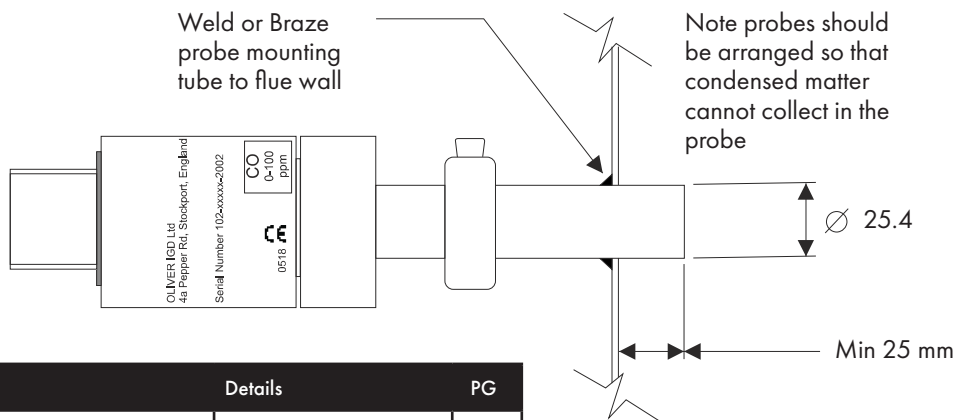

Article No.	Model	Details	PG
3500-0129	GLACIÄR X5 Type 3 Duct Adaptor welding	Welding, steel	G
3500-0104	GLACIÄR X5 Type 5 Duct Adaptor BSP	1" BSP threading, steel	G



SIMPLY RELIABLE REFRIGERANT GAS DETECTORS

www.samon.com

Part of **safe monitoring group**